

Special Triangles	Special Triangle Word Prob.	Trig. Ratios	Trig. Ratios Word Prob.	Challenge
<u>200</u>	<u>200</u>	<u>200</u>	<u>200</u>	<u>200</u>
<u>400</u>	<u>400</u>	<u>400</u>	<u>400</u>	<u>400</u>
<u>600</u>	<u>600</u>	<u>600</u>	<u>600</u>	<u>600</u>
<u>800</u>	<u>800</u>	<u>800</u>	<u>800</u>	<u>800</u>
<u>1000</u>	<u>1000</u>	<u>1000</u>	<u>1000</u>	<u>1000</u>

In a  $45^\circ-45^\circ-90^\circ$  triangle, if one leg is 5cm, what is the length of the other leg?

5 cm

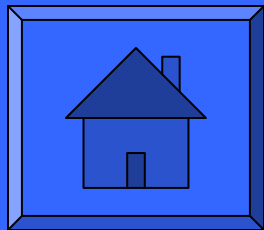

In a  $45^\circ-45^\circ-90^\circ$  triangle, if one leg is 6cm, what is the length of the hypotenuse?

$6\sqrt{2}$  cm

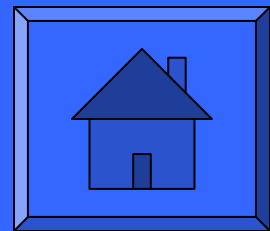

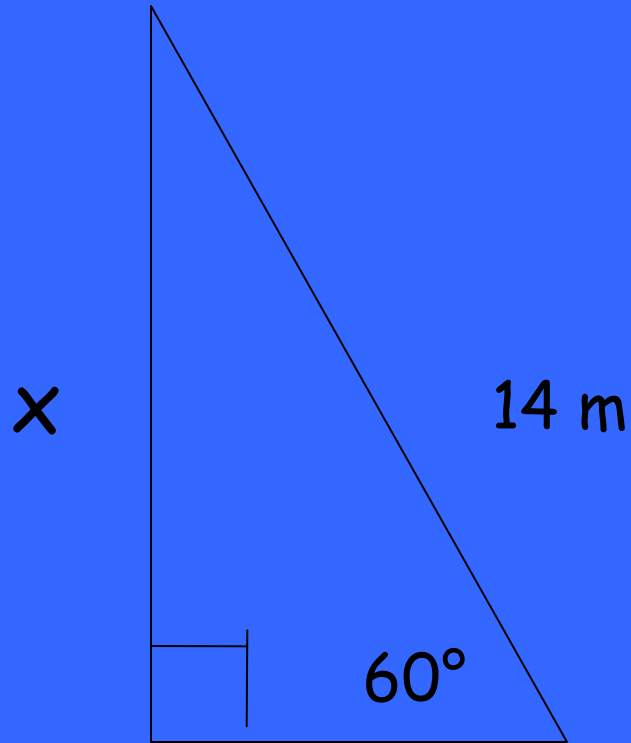

Find  $x$

$$X = 7\sqrt{3} \text{ m}$$

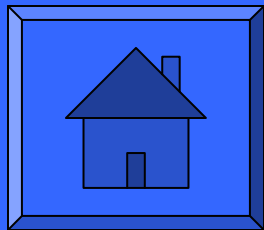

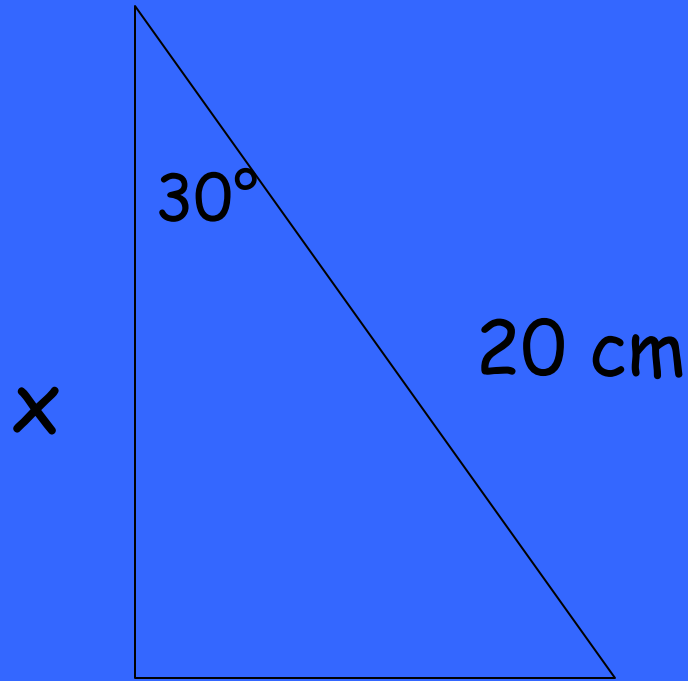

Find  $x$



$10\sqrt{3}$  cm

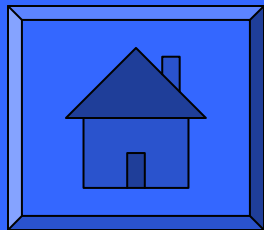

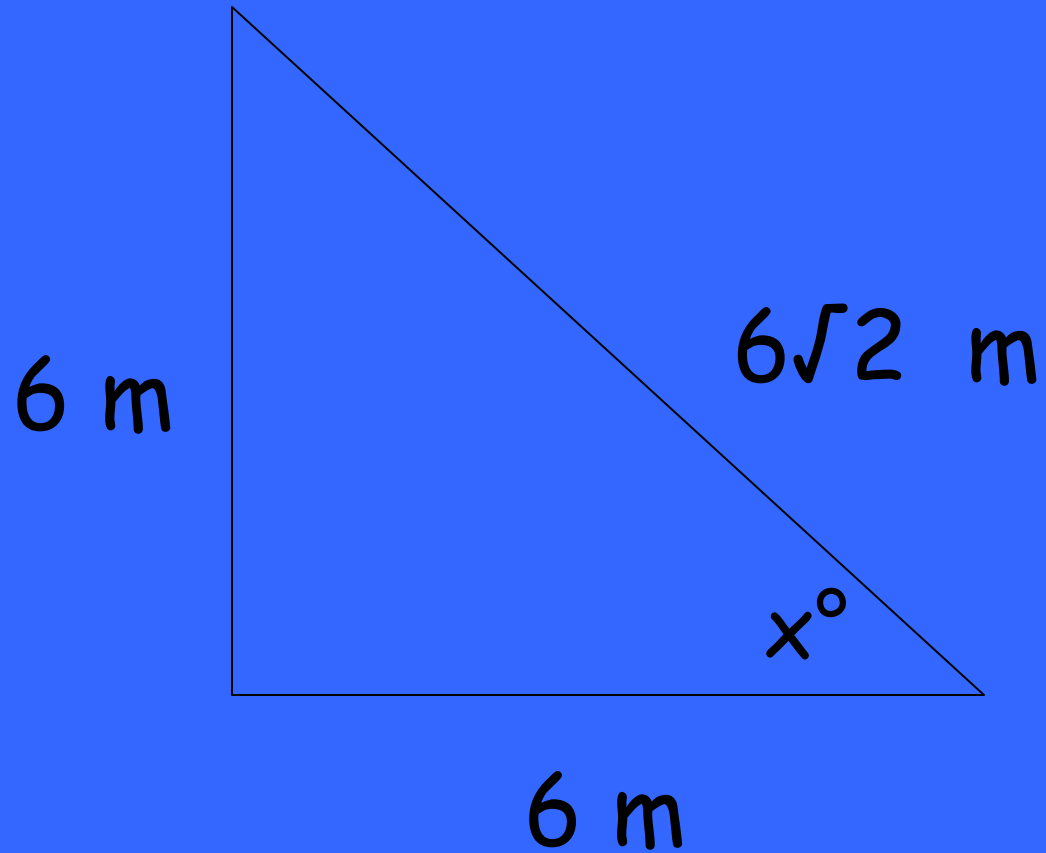

Find  $x^\circ$

$$X = 45^\circ$$

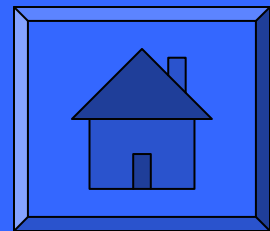

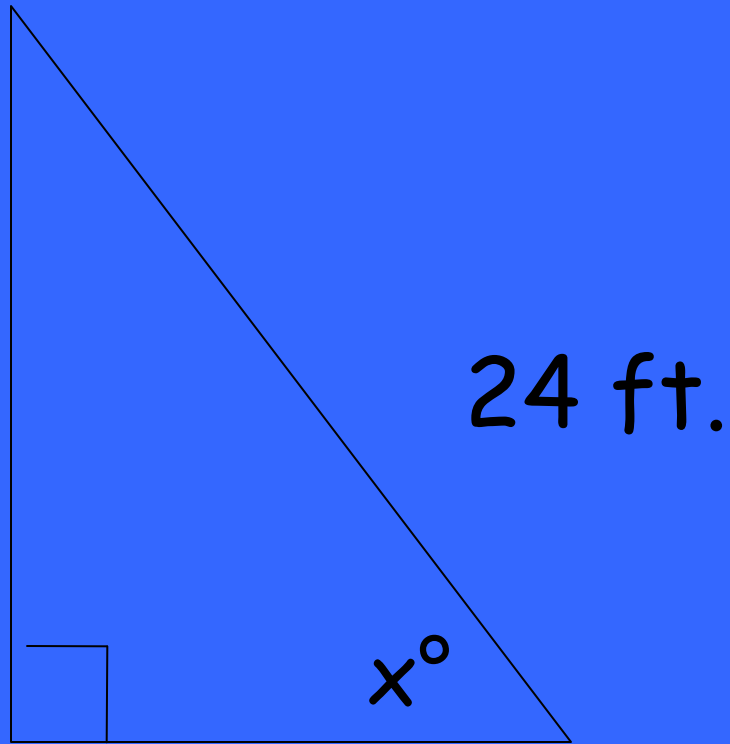

12 ft.

Find  $x^\circ$

$$X = 60^\circ$$

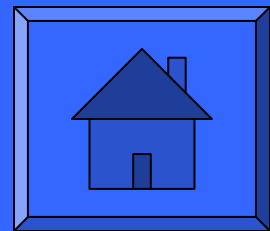

The length of one diagonal of a rhombus is 12 cm. The measure of the angle opposite that diagonal is  $60^\circ$ . What is the perimeter of the rhombus?

The perimeter of the rhombus is 48 cm.

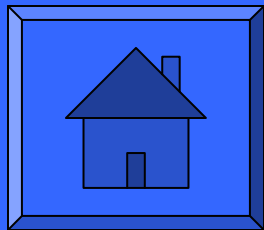

The angle formed by the roof of a monument measures  $60^\circ$ . Since this is such a steep angle, an architect places a support beam at a slant distance of 8 ft. along the roof from the corner. How tall is the support beam? Leave answer in radical form.

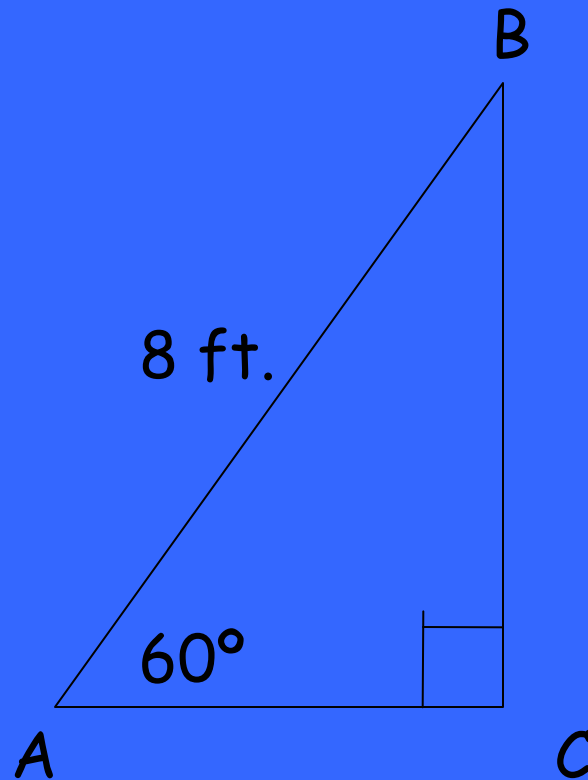



The support beam  
is  $4\sqrt{3}$  ft. tall.

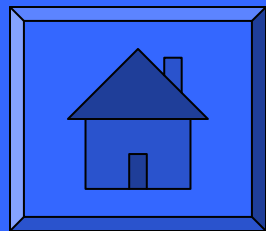

Mark tries to swim across a river from point  $A$  to point  $B$ . Because of the current, he reaches point  $C$  instead. How far does he swim? Leave answer in radical form.

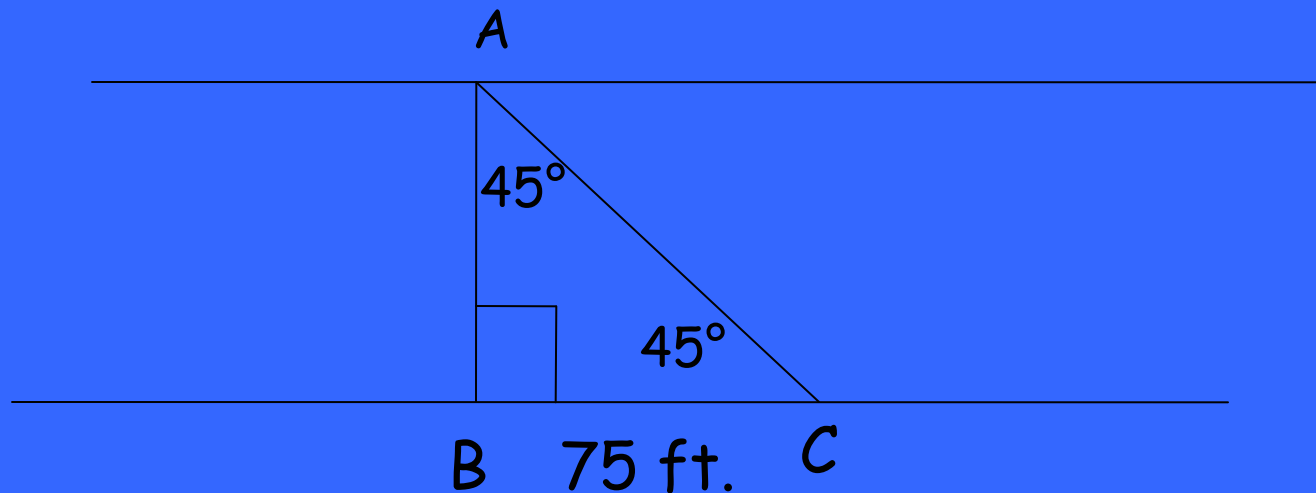

Mark swam  $75\sqrt{2}$  ft.

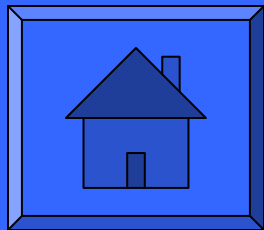

A baseball diamond is a square with sides that are 90 ft. long. Find the distance from first base to third base. Leave the answer in radical form.

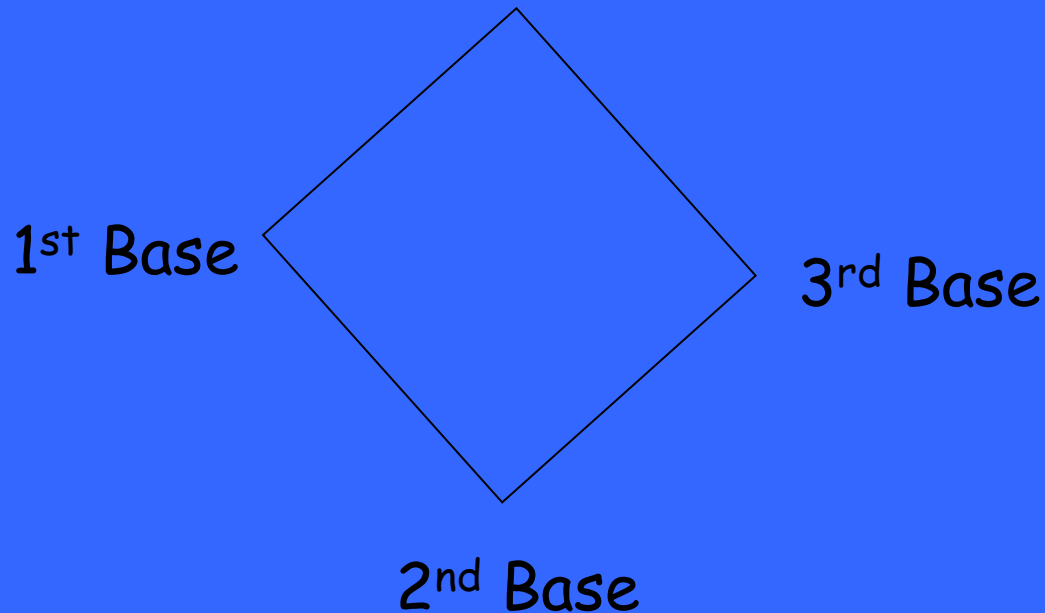

The distance from 1<sup>st</sup>  
base to 3<sup>rd</sup> base is  
 $90\sqrt{2}$  ft.

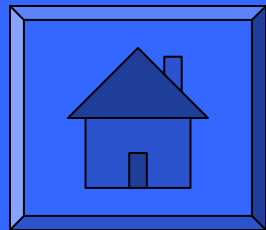

The length of a kite string fastened to the ground is 86 m. The vertical height of the kite is 43 m. Find the angle that the string makes with the ground. Leave your answer in radical form.

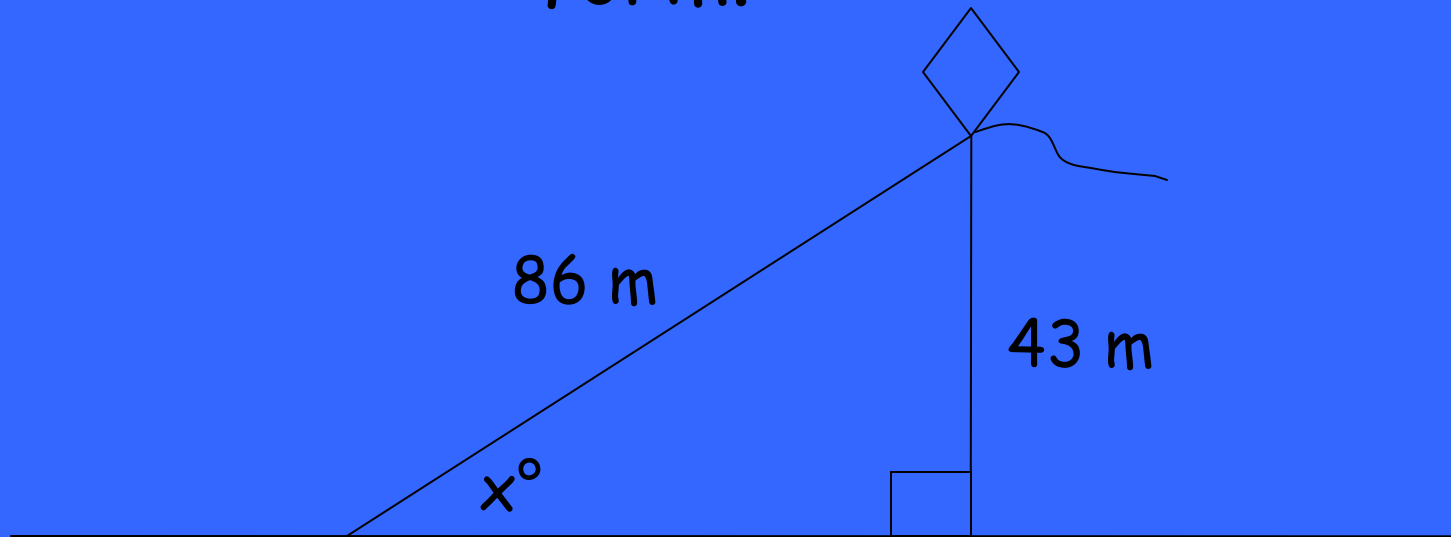

The string makes  
a  $30^\circ$  angle with  
the ground.

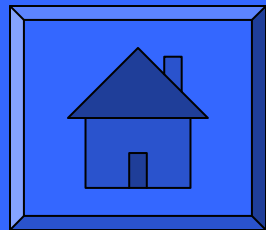

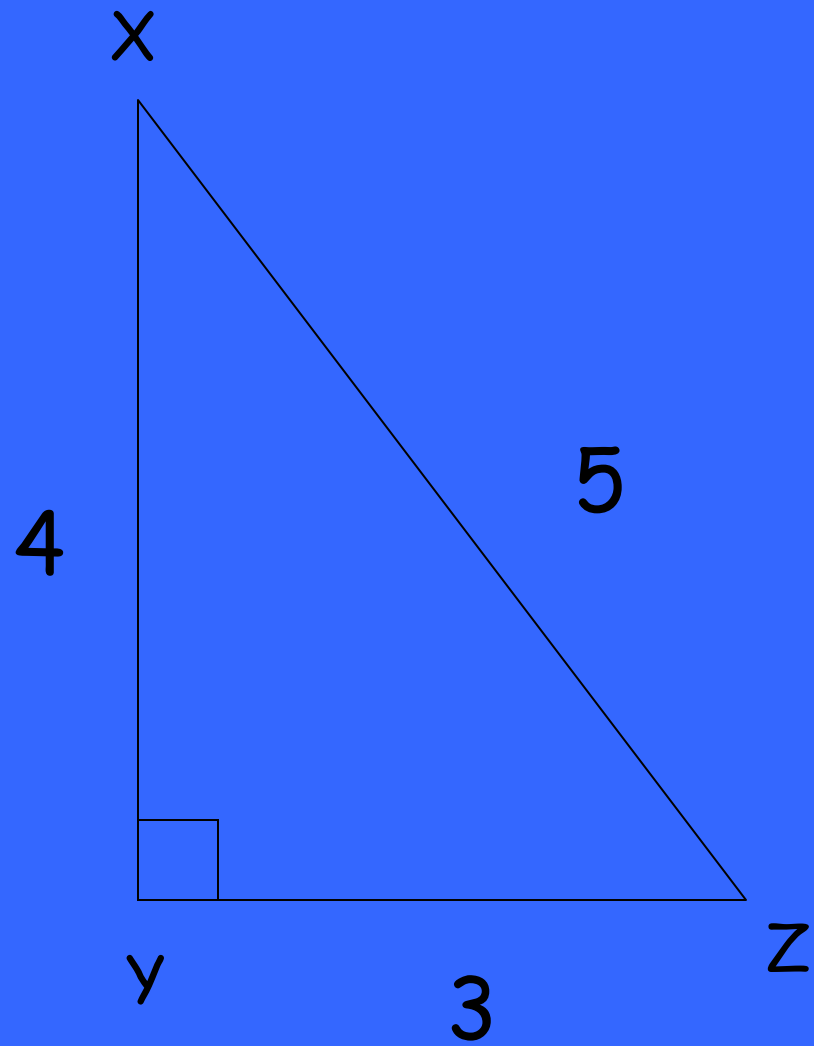

Find the  $\sin Z$



$$\begin{aligned} \text{The } \sin y \\ = 4/5 \end{aligned}$$

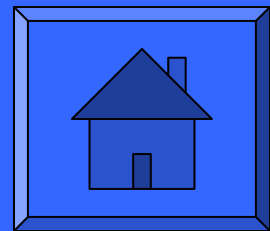

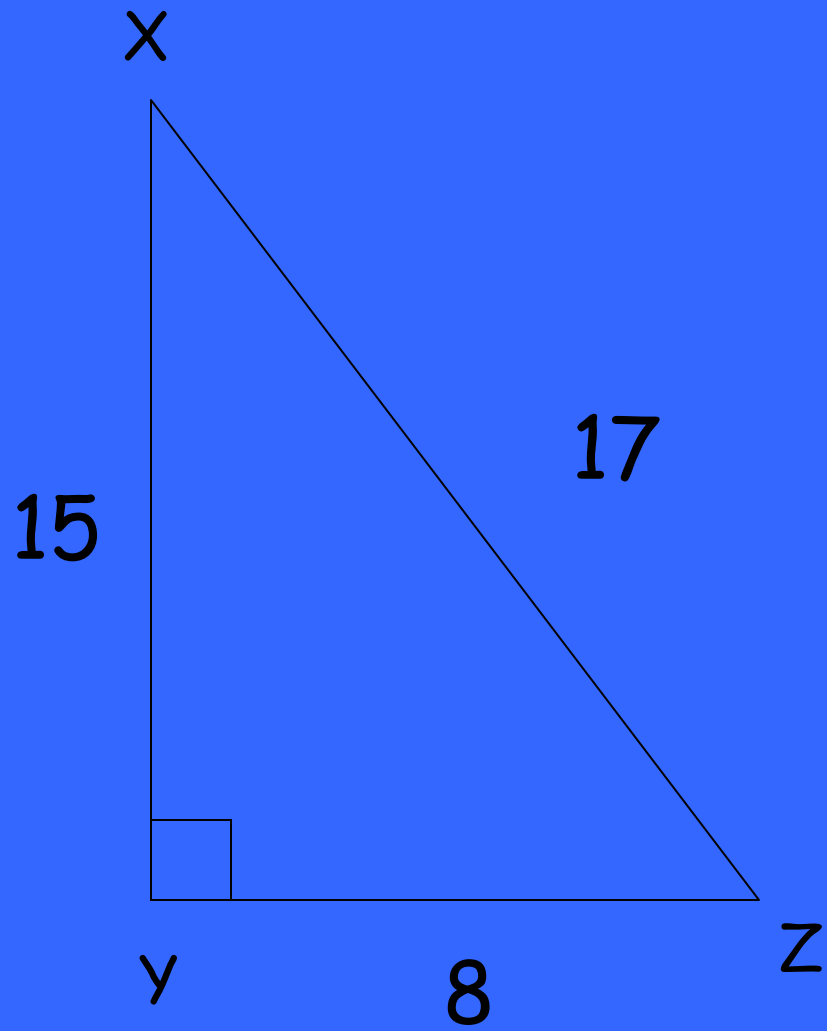

Find the  $\cos x$

$$\begin{aligned} \text{The } \cos x \\ = 15/17 \end{aligned}$$

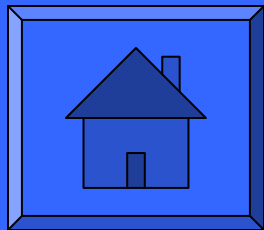

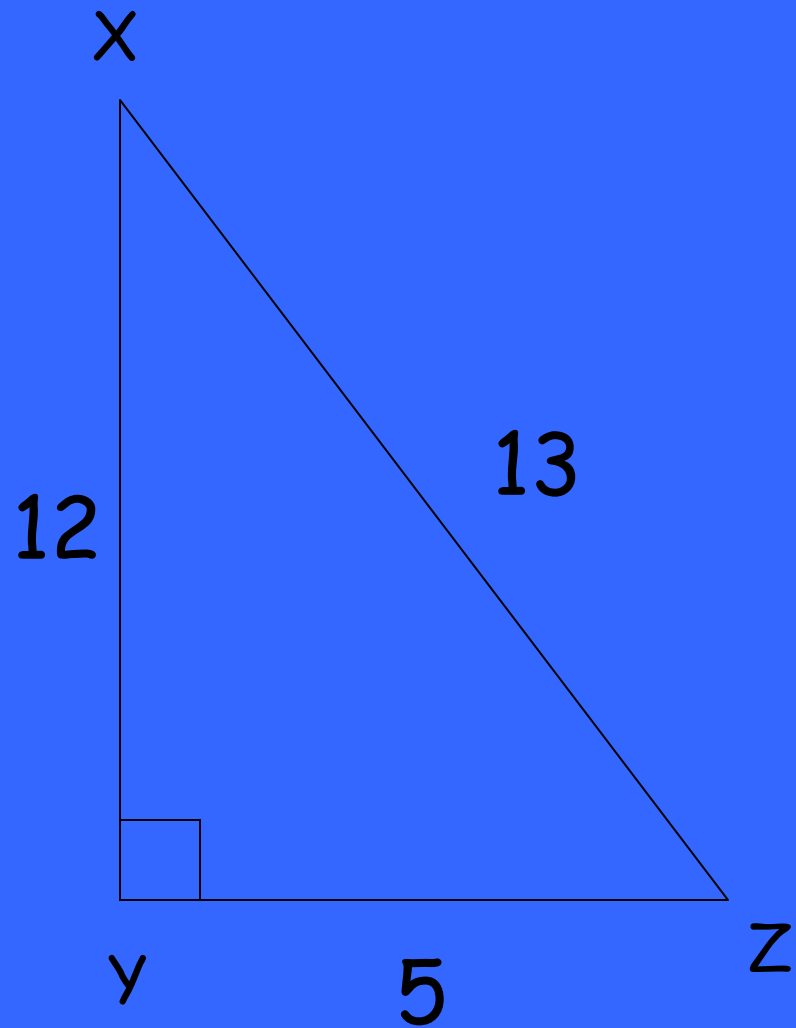

Find the  $\tan z$

The  $\tan z = 12/5$

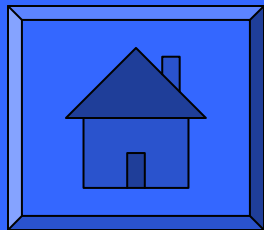

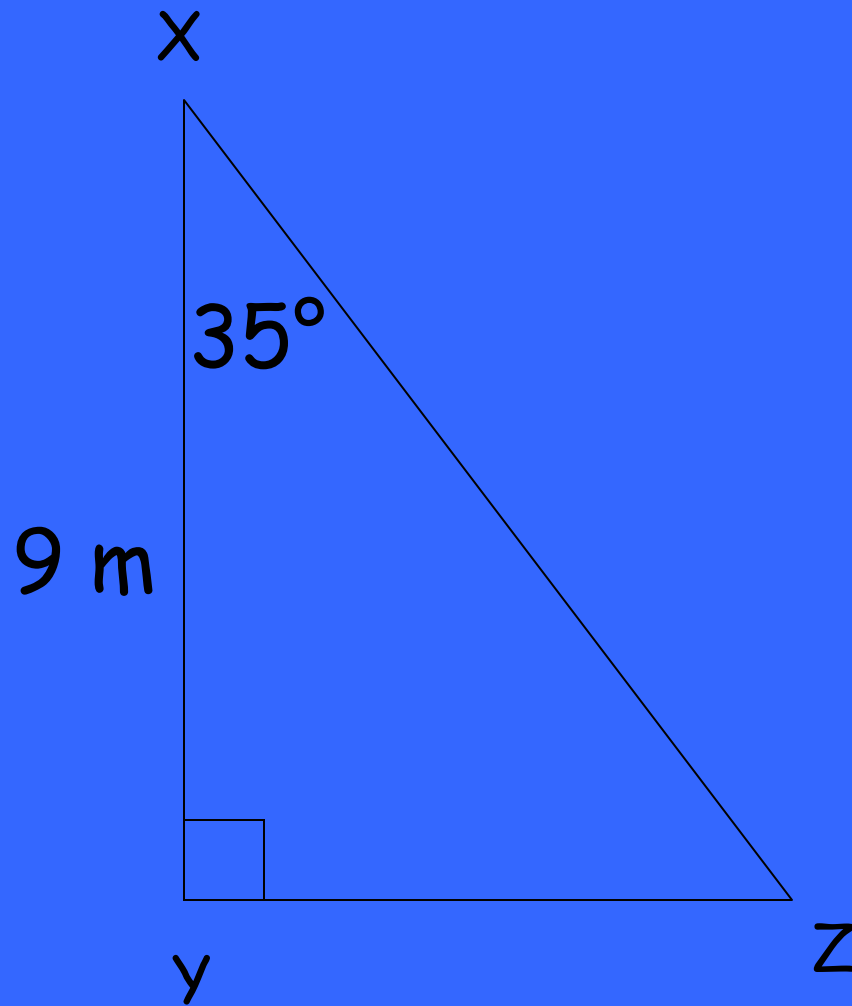

Find the area of triangle  $XYZ$   
Leave answer in radical form.

The area of the  
triangle is  
 $28.358 \text{ m}^2$

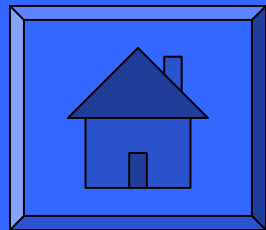

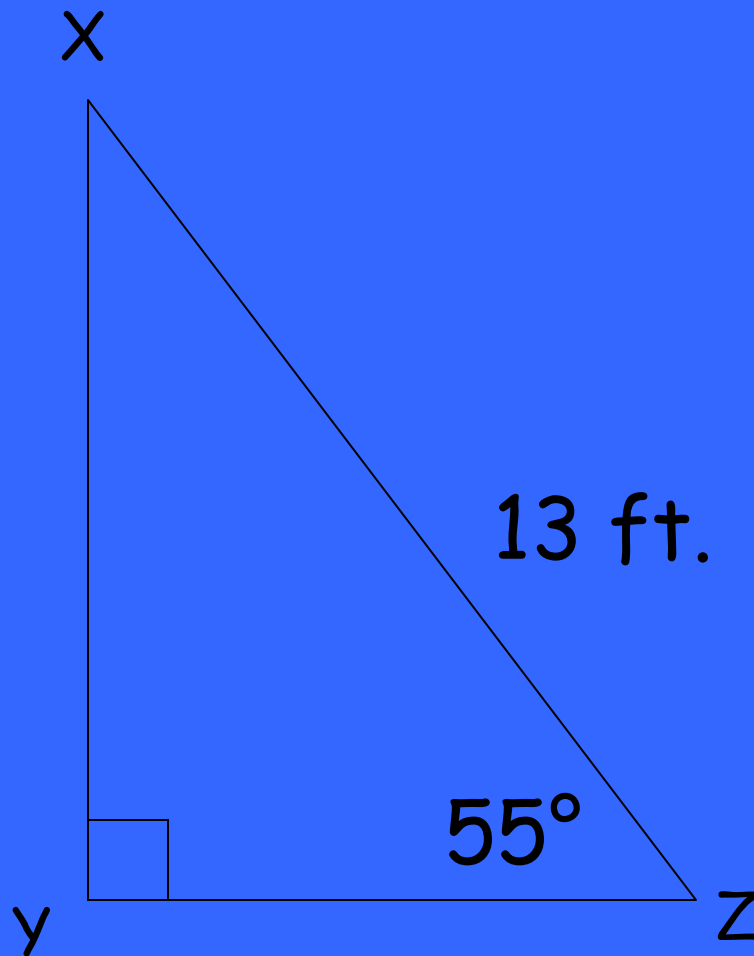

Find the perimeter of triangle  $XYZ$   
Leave answer in radical form.



The perimeter of  
the triangle is  
approximately  
31.105 ft.

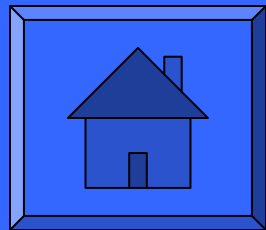

A photographer is taking pictures of two islands from a plane. When the plane is directly above Green Island, the line of sight to Red Island forms a  $55^\circ$  angle. How high above Green Island is the plane?

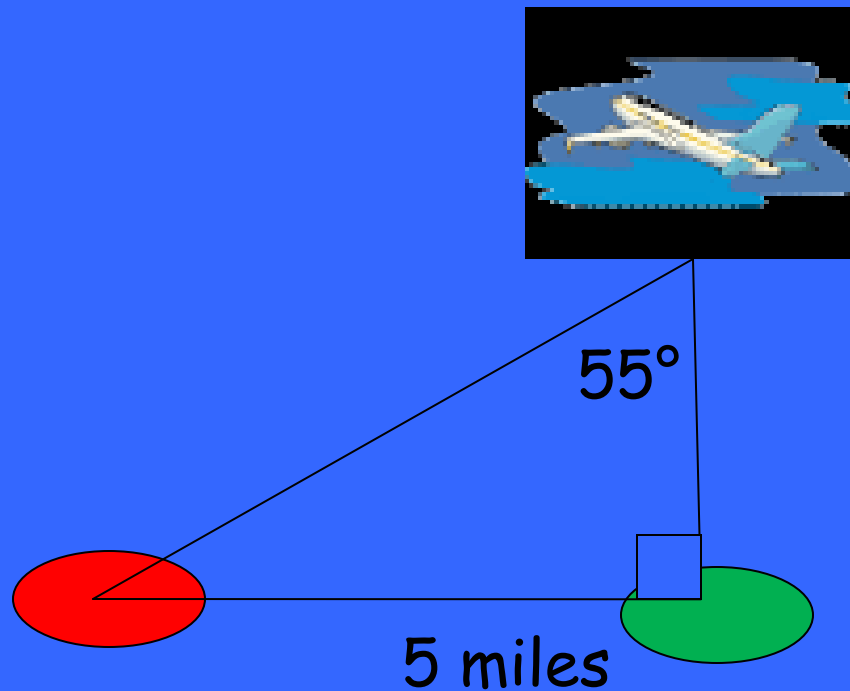

The plane is approximately  
3.5 miles  
above the Green Island.

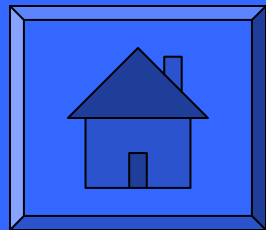



All but two Egyptian pyramids have faces that are inclined at  $52^\circ$  angles. An archaeologist

finds an eroding pyramid with a square base having a side length of 84 m. How tall was the pyramid, if the faces are inclined at  $52^\circ$ ?

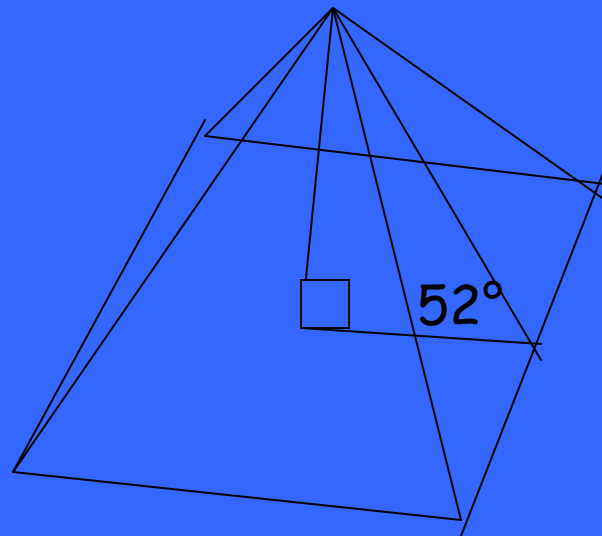

The height of the pyramid is approximately 53.75 m.

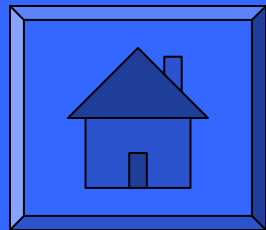

Amanda and Tom are given the task of designing a ramp, so that people in wheelchairs can get into the Skiles Classroom Building. The rise has to be 5 feet and the angle of the ramp has to be  $15^\circ$ . How long does the ramp have to be?

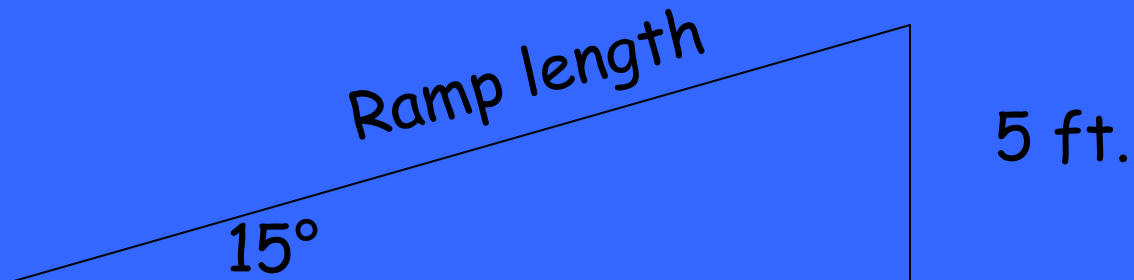

The ramp will be  
approximately  
19.32 feet.

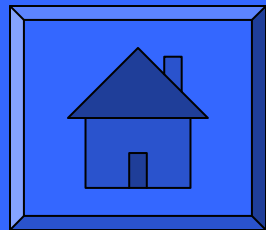

A ladder is leaning against a building as shown below. The ladder reaches a height of  $7\sqrt{3}$  on the building. The ladder makes an angle of  $30^\circ$  with the wall. How long is the ladder?

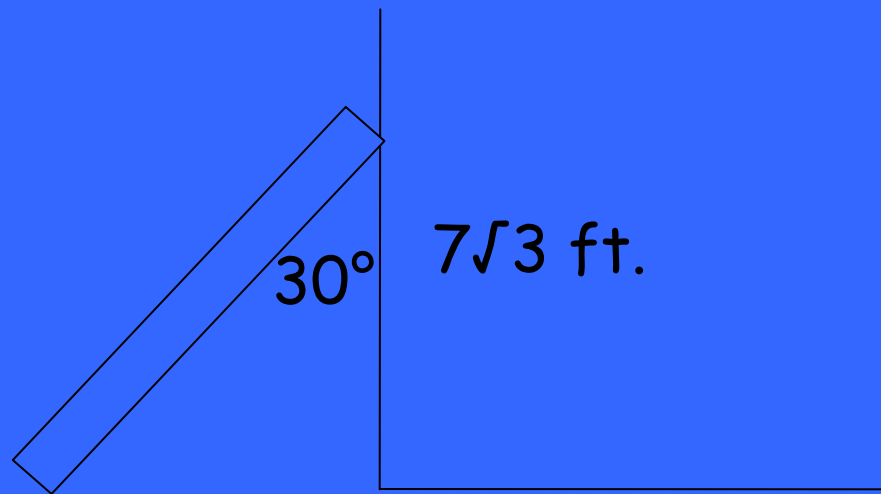



The ladder is 14 feet long.

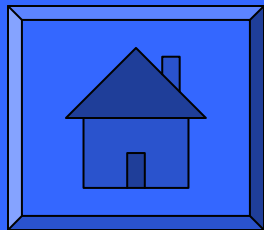

A lighting technician needs to shine a spotlight onto an actor's face. The light being directed is attached to a ceiling that is 12 feet above the actor's face. At an angle of  $40^\circ$ , how far away from the actor should the light be?

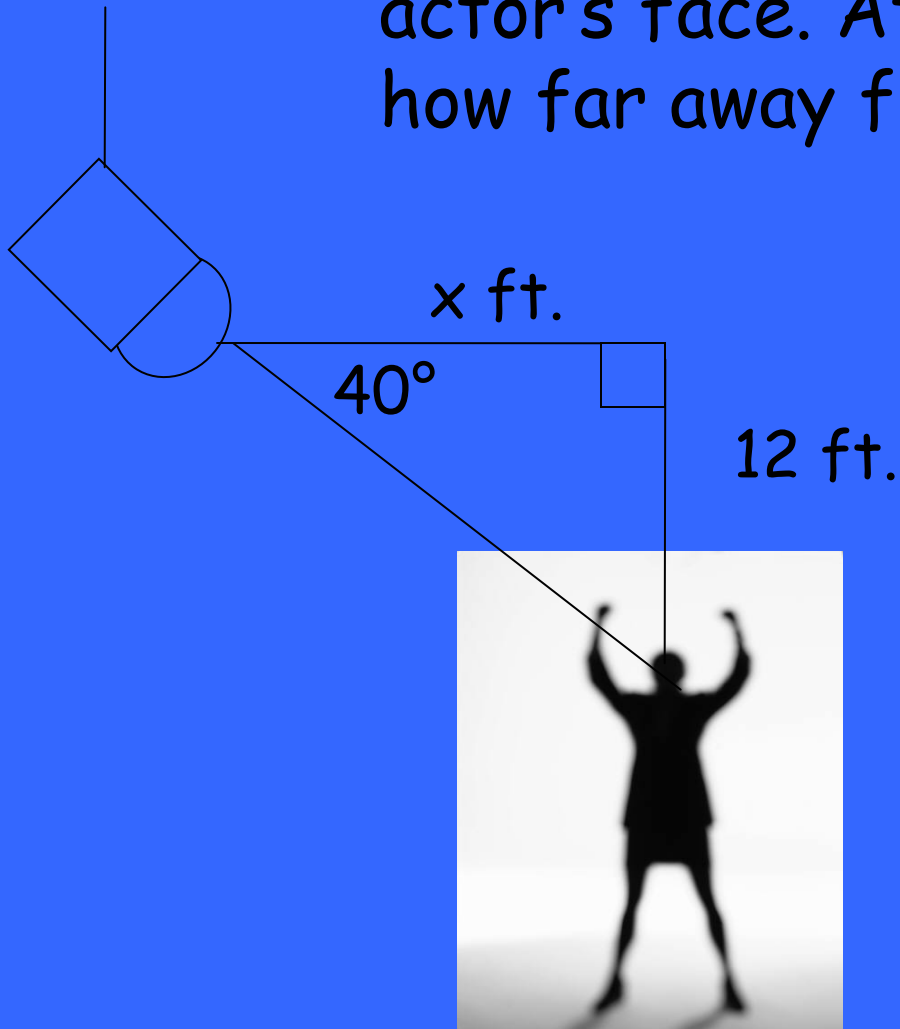

The actor should be  
approximately  
14.3 feet away  
from the spotlight.

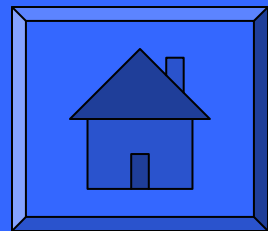

A 15-ft. ladder leaning against a wall makes a  $54^\circ$  angle between the ground and the ladder. To the nearest foot, how far up the wall does the ladder reach?

The ladder is  
approximately  
12.14 ft.  
up the side of  
the building.

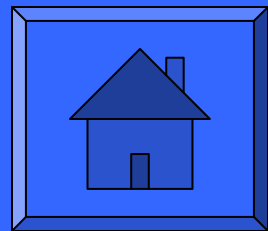

John and Alex are standing on one side of the river. Alex stands directly in front of a monument they see on the other side of the river. Using a compass, Alex walks along the river in a direction perpendicular to his original line of sight until the compass reading has changed by  $45^\circ$ . John measures the distance Alex walked as 30 m. What is the width of the river?

The river is 30 m  
wide.

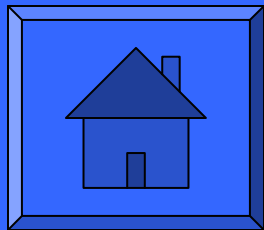

In a right triangle the two complementary angles are  $\angle A$  and  $\angle B$ .

What is the relationship between the sine and cosine of these angles?



The  $\sin A = \cos B$  and  
 $\sin B = \cos A$ .

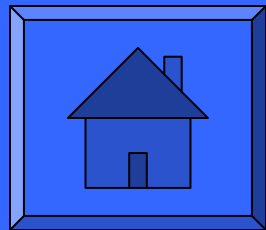

An airport is tracking the path of one of its incoming flights. If the distance to the plane is 850 ft. and the angle of elevation from the ground is  $30^\circ$ , what is the altitude of the plane?

The plane is  
approximately  
flying at an  
altitude of  
490.75 ft.

